

DATA SHEET

**VT 4.40**

# ROTARY VANE VACUUM PUMPS

oil-free

air-cooled

---

**MAKE IT BECKER.**



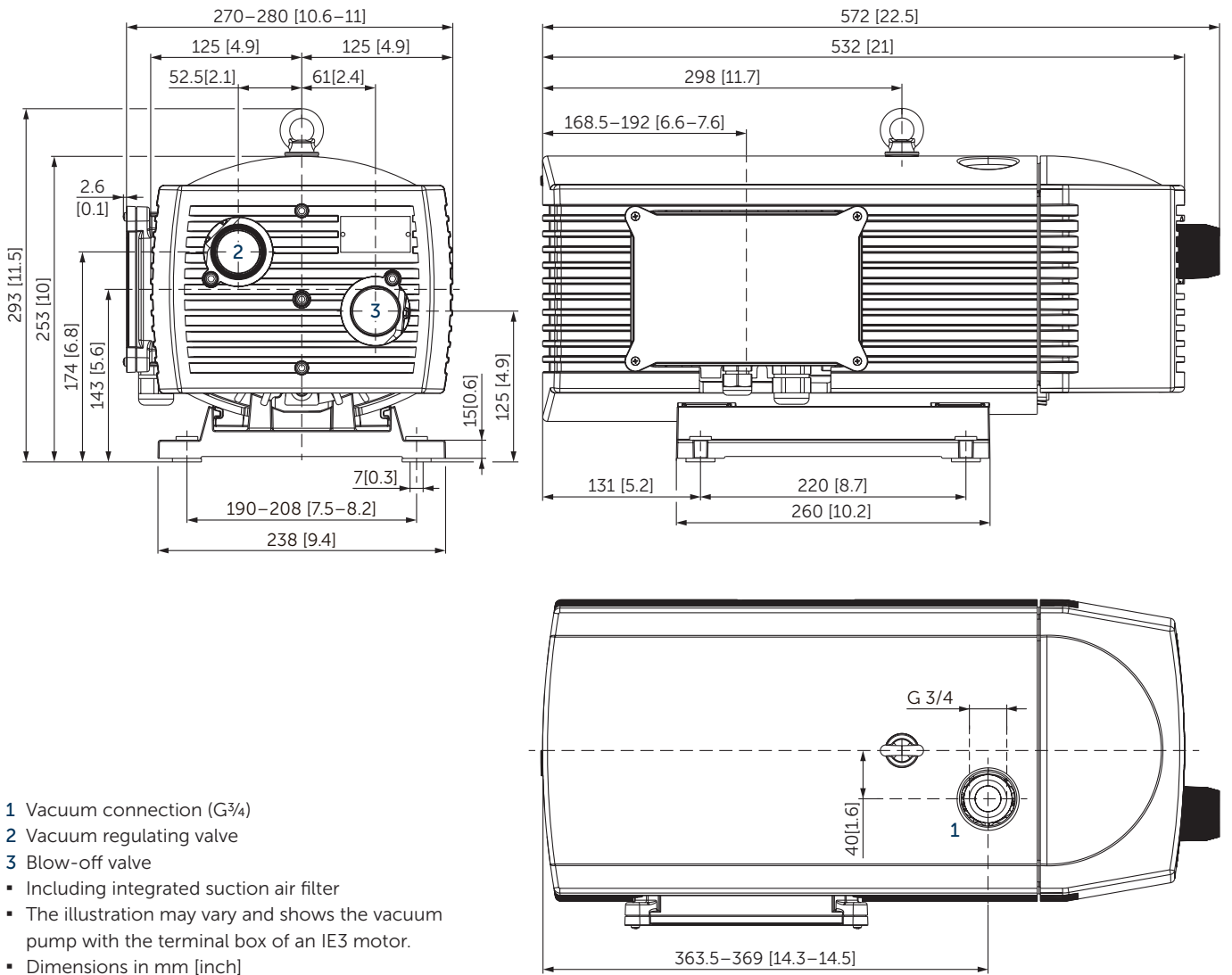

- 1 Vacuum connection (G<sup>3</sup>/<sub>4</sub>)
- 2 Vacuum regulating valve
- 3 Blow-off valve
  - Including integrated suction air filter
  - The illustration may vary and shows the vacuum pump with the terminal box of an IE3 motor.
  - Dimensions in mm [inch]

Suction air rate		Vacuum absolute		Motors 3~		Emission sound pressure level <sup>1)</sup>		Weight with motor kg
m <sup>3</sup> /h		mbar		kW		dB(A)		
50 Hz	60 Hz	50 Hz	60 Hz	50 Hz	60 Hz	50 Hz	60 Hz	
40	48	150	150	1.25-1.3	1.5	67	72	≈38-41 <sup>2)</sup>

<sup>1)</sup> According to DIN EN ISO 3744 (KpA = 3 dB(A)), 1 m [39.4 inch] distance, at medium load, both connection sides piped

<sup>2)</sup> Depending on the motor

3~ Motors											
#	50 Hz					60 Hz					Version
	kW	V	min <sup>-1</sup>	A		kW	V	min <sup>-1</sup>	A		
01	1.3	Y400	IE3	1435	3.1		YY230/Y460	IE3	1735	5.8/2.9	UL(E113150)/CSA/CC046A IP55, ISO F PTO (bimetal) 150°C
						1.5	YY208	IE3	1720	6.5	
							Y400	–	1715	3.3	
02	1.3	Δ200/Y350	IE3	1435	6.4/3.7	1.5	Δ220/Y380–400	IE3	1735	6.1/3.5	UL(E113150)/CSA IP55, ISO F PTO (bimetal) 150°C
							Δ200/Y350	–	1720	6.4/3.7	
03	1.25	190–255/ 330–440	–	1430	5.2–6.2/ 3.0–3.6	1.5	190–290/ 330–500	–	1680	6.9–5.7/ 4.0–3.3	IP54, ISO F bimetal 150°C
04	1.25	190–255/ 330–440	–	1430	5.2–6.2/ 3.0–3.6	1.5	190–290/ 330–500	–	1680	6.9–5.7/ 4.0–3.3	UL/CSA IP54, ISO F bimetal 150°C

1~ Motor <sup>1)</sup>											
#	50 Hz					60 Hz					Version
	kW	V	min <sup>-1</sup>	A		kW	V	min <sup>-1</sup>	A		
01	1.1	230 ±10%	1350	7.6		1.1	230 ±10%	1620	7.3		IP54, ISO F, bimetal 150°C 30 μF (400 V)

<sup>1)</sup> Note reduced power of the 1~ motor!

• Current consumption and rotation speed may vary. Tolerance in each case -1.5/+2%

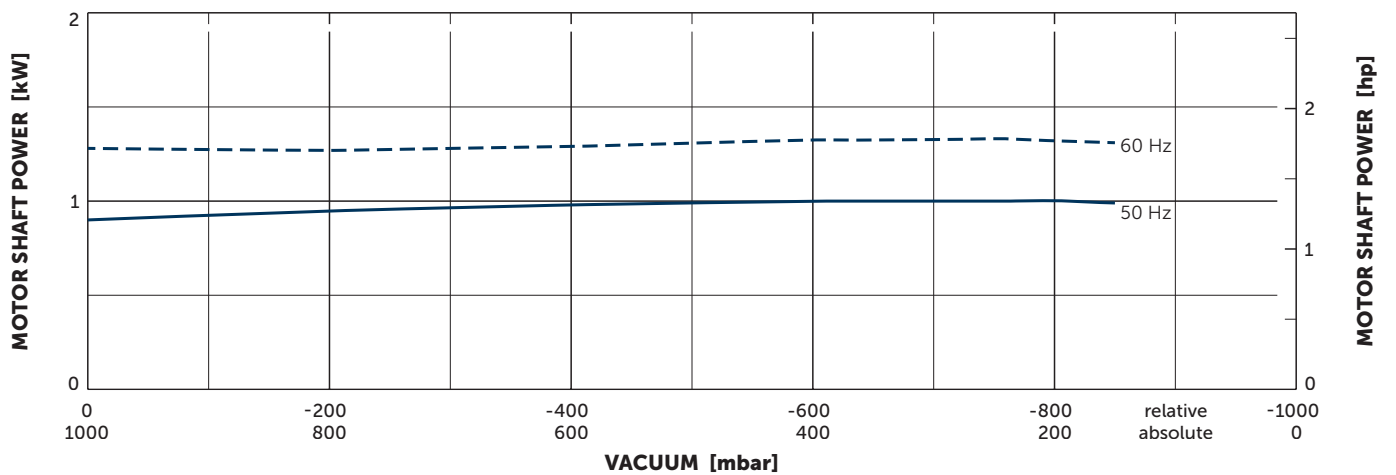
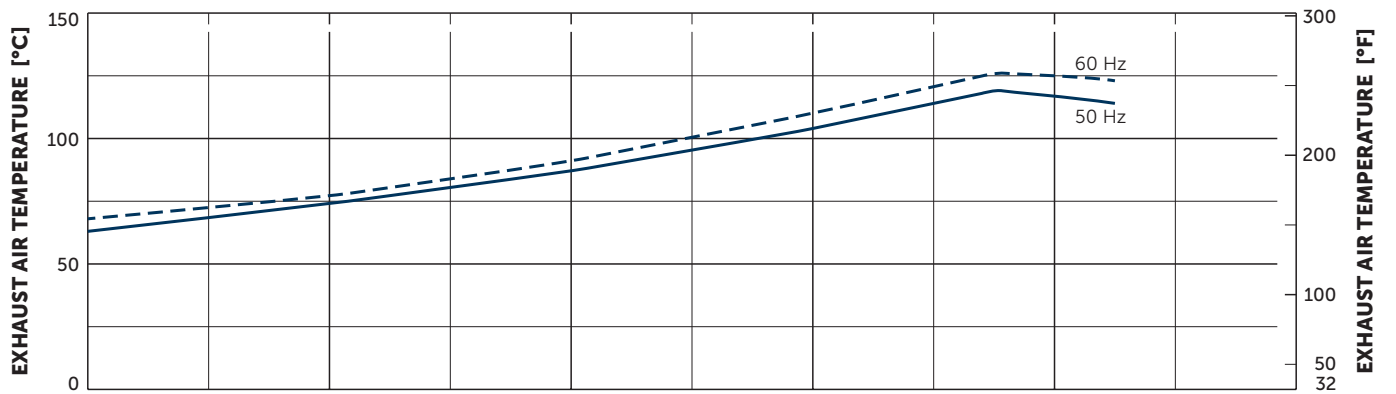
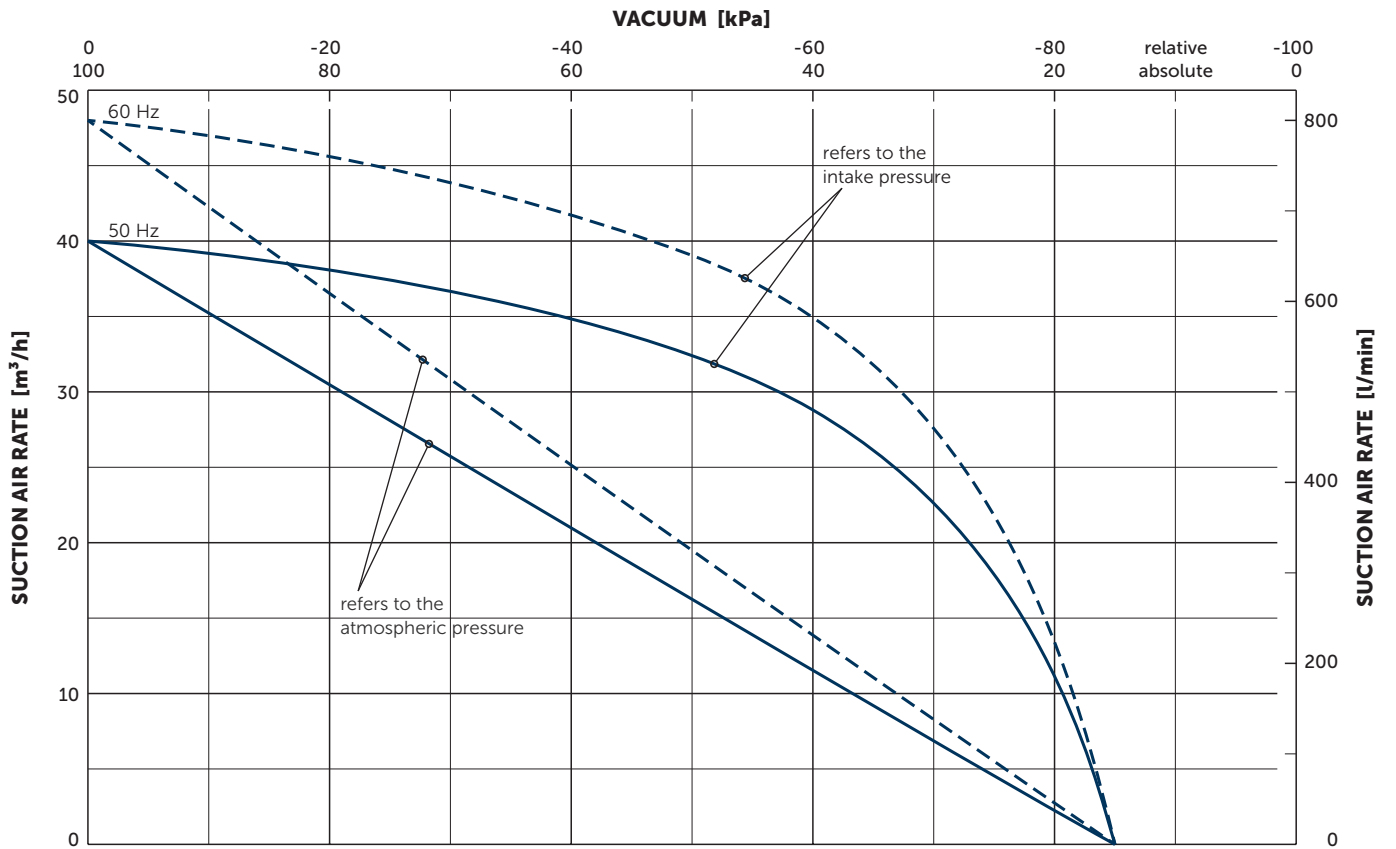

Reference data (atmosphere): 1000 mbar (100 kPa), 20°C (68°F)  
 Tolerance: ±5%  
 Air temperature: 5°C ... 45°C (41°F ... 135°F)

## + VARIANTS AND ACCESSORIES

### VX 4.40

#### SERIES X: BECKER INNOVATION WITH TOP WARRANTY

Equipped with specially developed vanes, these oil-free rotary vane pumps distinguish themselves by high abrasion resistance, and with that extremely long service lives. Due to the low wear there is also minimal dust, so the series X pumps are perfectly suited for precision processes under clean room conditions.

This innovation branded by Becker is outstanding not only because of its 100 percent oil-free operation, excellent degree of efficiency and low power consumption.

In the area of sensitive vacuum, series X also guarantees precise low-pulsation air conduction.

Becker guarantees for these pumps a vane life-time of 20,000 operating hours or a maximum of 3 years. The enhanced longevity of X series pumps also extends service life intervals, and can cut out the need for frequent service visits with costly pump failures now no longer an issue.



#### ADVANTAGES

- Quick, clean and quiet
- Oil-free
- Wear resistant
- Energy saving
- Long-life reliability
- Ultimate pressure 100 mbar absolute

### OTHER VARIANTS AND ACCESSORIES

- **VT 4.40/0-90** with a higher suction air rate of maximum 47/55 m<sup>3</sup>/h (50/60 Hz)<sup>1)</sup>
- With external suction filter, e.g. series FV<sup>1)</sup>
- Sound proof box SH 19<sup>1)</sup>



Example for an external suction filter



Sound proof box SH 19

<sup>1)</sup> See separate data sheet

- Possible combinations on request



**MAKE IT BECKER.**