

## Ran<sup>®</sup> 1" (25.4 mm)

PVDF Body Diaphragm Pump



### Technical Specifications

Pump Code	D25-PV1-2
Max. Flow Rate	170 lpm
Max. Pump Speed	280 cpm
Displacement per cycle	0.61 liter
Fluid Inlet- Outlet Size	1" ANSI Flange
Air Inlet Size	3/8"
Max. Fluid Working Pressure	8 bar
Max. Air Consumption (at 5 bar)	1 m <sup>3</sup> /min
Ratio	1:1

Pump Housing Material	PVDF
Center Section Material	Polypropylene
Max. Size Pumpable Solids	3 mm
Max. Suction Lift	9.5 m (Wet) 5 m (Dry)
Max. Operating Temperature	104°C
Sound Level	75 dBA (at 5 bar)
Diaphragm Material	PTFE/TPE
Check-Valve Material	PTFE
Weight	11 kg

### Performance Curves

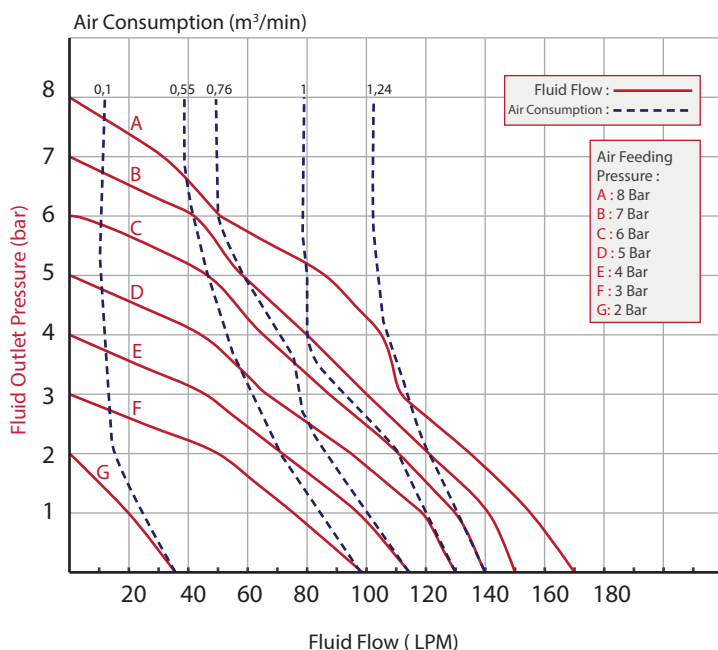

Made in Turkey



**Test Conditions:** All tests are made with water. Suction hose submerged in the fluid. Muffler not used. All the values are shown are approximate and not binding.

**Example:** To pump 80 lpm against a discharge pressure of 4 bar, requires 7 bar and 1 m<sup>3</sup>/min air consumption.

### Dimensions

A	308
B	507
C	107
D	16
E	378
F	210
G	198
H	150
I	11

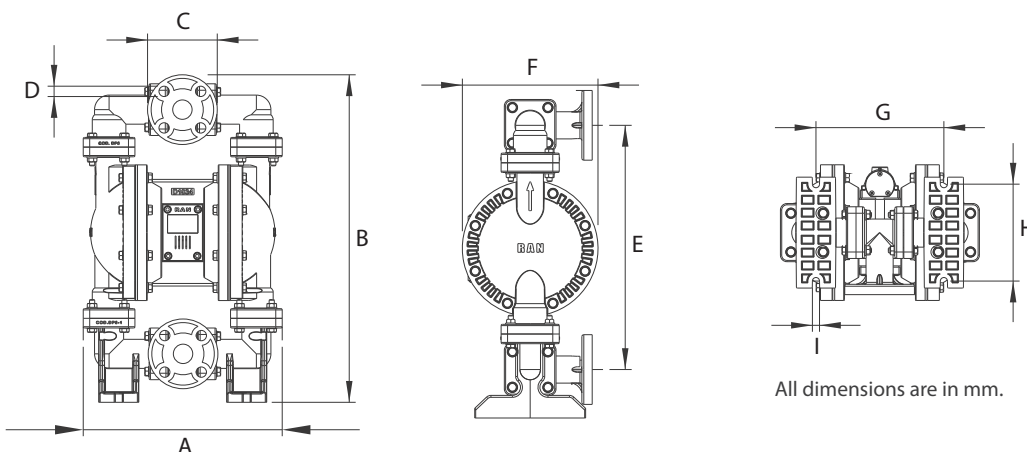

All dimensions are in mm.