







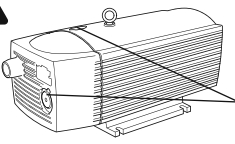

BETRIEBSANLEITUNG
OPERATING INSTRUCTIONS
INSTRUCCIONES DE SERVICE
ISTRUZIONI D'USO
HANDLEIDING
INSTRUCCIONES PARA EL MANEJO
MANUAL DE INSTRUÇÕES
NAUDOJIMOSI INSTRUKCIJA
KASUTUSJUHEND
LIETOŠANAS INSTRUKCIJA
DRIFTSINSTRUKS
DRIFTSINSTRUKTIONER
DRIFTSVEJLEDNING
INSTRUKCJA OBSŁUGI

KEZELÉSI ÚTMUTATÓ
NÁVOD K OBSLUZE
NAVODILO ZA UPORABO
NÁVOD NA OBSLUHU
UPUTE ZA RAD
MANUAL DE OPERATII
TREORACHA OIBRIÚCHÁIN
ΟΔΗΓΙΕΣ ΧΡΗΣΗΣ
EL KITABI
ИНСТРУКЦИИ ЗА ЕКСПЛОАТАЦИЯ
ИНСТРУКЦИЯ ПО ЕКСПЛОАТАЦИИ
取扱説明書
사용설명서
使用说明书



VT 4.25

MAKE IT BECKER.





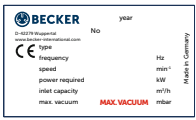

 			
			
 <p>AIR</p>			
			



1

 <p>MAX. VACUUM</p>		<p>mbar</p>	
	 <p>MAX.</p>		
<p>DIN EN ISO 11203 Accuracy Class 2 K_{pA} = 3 dB(A) l_r = 1m</p>		<p>L_{pA} = 62 dB(A) - 50Hz L_{pA} = 67 dB(A) - 60Hz K_{pA} = 3 dB(A)</p>	

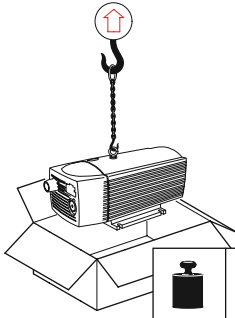

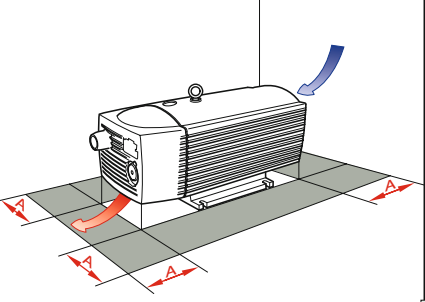

2

			
<p><input checked="" type="checkbox"/></p>	<p><input type="checkbox"/></p>	<p><input type="checkbox"/></p>	<p><input type="checkbox"/></p>
			
			<p>26 kg 57 lbs</p>

3

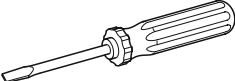
<p>A > 100mm A > 4"</p>	 <p>> 5°C/41°F < 45°C/113°F</p>	 <p>max. 90%</p>	 <p>max. 800m</p>
			

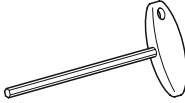
4

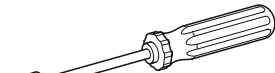
 <p>6 mm</p>	
 <p>5 mm</p>	
 <p>7 mm</p>	

5

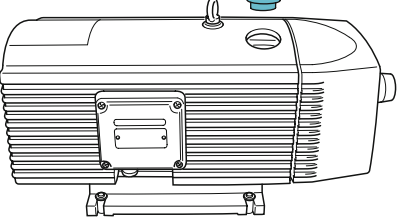
6

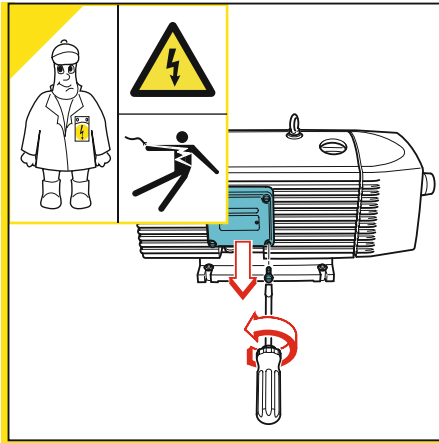

7

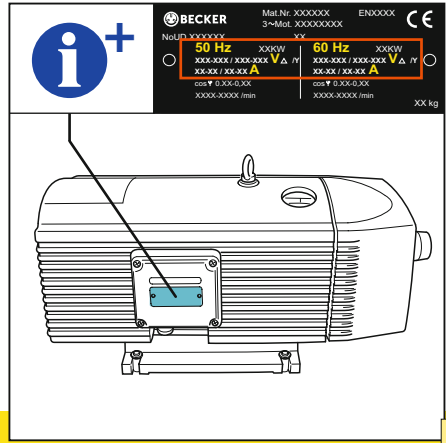

8

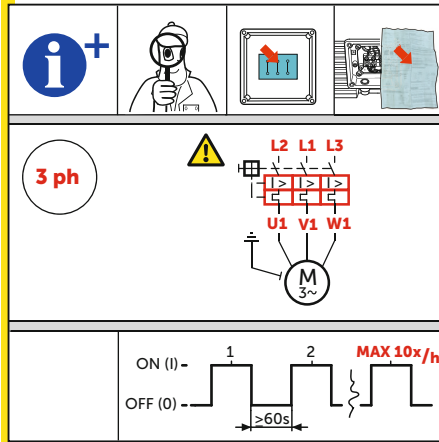

9

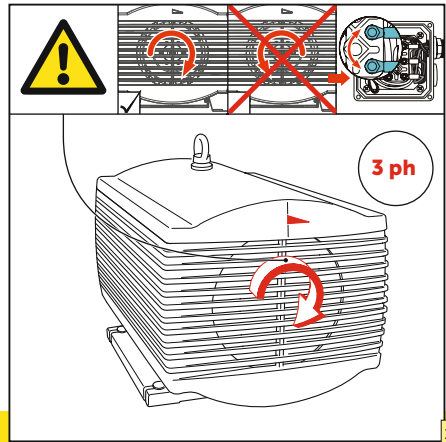

10

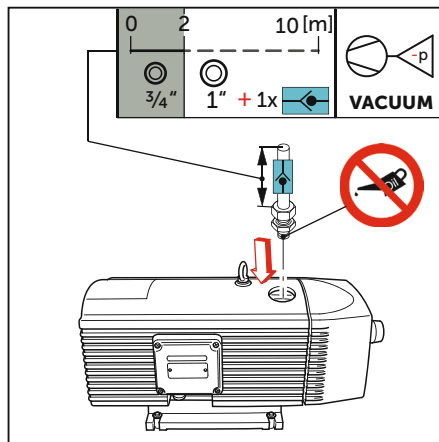

11

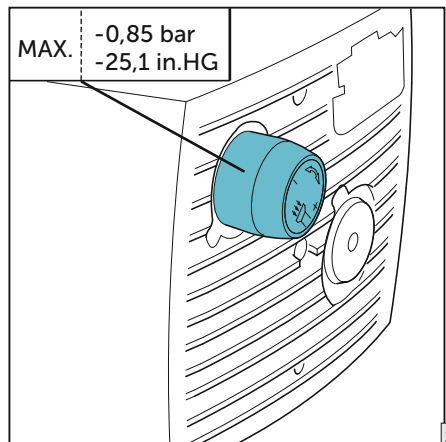

12

Maintenance



n=0min⁻¹

2-3 Min



13

14

3x		A	<input checked="" type="checkbox"/>	6.2Nm
2x		-X	<input type="checkbox"/>	2Nm

15

F1



	SUCTION AIR		40h	
CLEANING INTERVAL			200h	

16

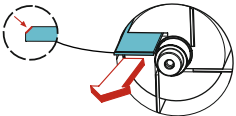
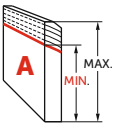

F1: D: 64 mm
H: 70 mm
No.: 90950500000

17

18

 <p>3000 h</p>	
	<p>$A_{MAX} = 43mm$</p> <p>$A_{MIN} = 28mm$</p> <p>$A_{T} < 28mm$  </p>
<p>VT 4.25 → No. 90134900007 (SET)</p>	

19

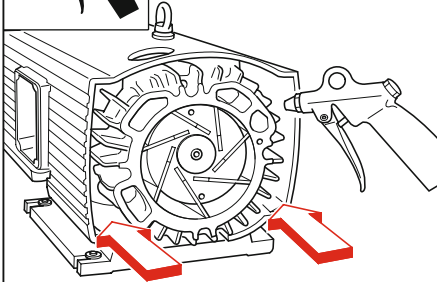
 	
---	---

20

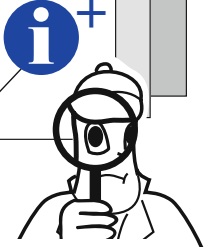
	
<p>www.becker-international.com</p>	

21

 <p>WWW.BECKER-INTERNATIONAL-SHOP.COM</p>

<p>Gebr. Becker GmbH Hoelker Feld 29-31 42279 WUPPERTAL GERMANY info@becker-international.com www.becker-international.com</p> 
--



MAKE IT BECKER.

28100027502 | 2020-02-24 | Alle Rechte vorbehalten